

Micromachining Using Femtosecond Laser Pulses

Qiumei Bian, Shouyuan Chen,
Shuting Lei, Zenghu Chang

Industrial and Manufacturing
Systems Engineering Department
& Physics Department
Kansas State University

Objective

The overall goal is to develop micro/nanoscale machining techniques using phase controlled ultrashort laser pulses for various applications

- ❑ **Fundamental study:** To understand the underlying physical mechanisms of the interaction between ultrashort-pulse laser and various types of materials
- ❑ **Process Development:** To develop novel micro/nanostructuring and surface patterning processes

Advantages of Femtosecond Laser Micromachining

- Non-contact machining
- High peak powers in the range of $\sim 10^{13}$ W/cm²
- Minimal thermal damage to surroundings
- Clean cuts with high aspect ratios
- Sub-micron feature resolution
- Minimal redeposition

Deep Microdrilling by Femtosecond Laser Pulses

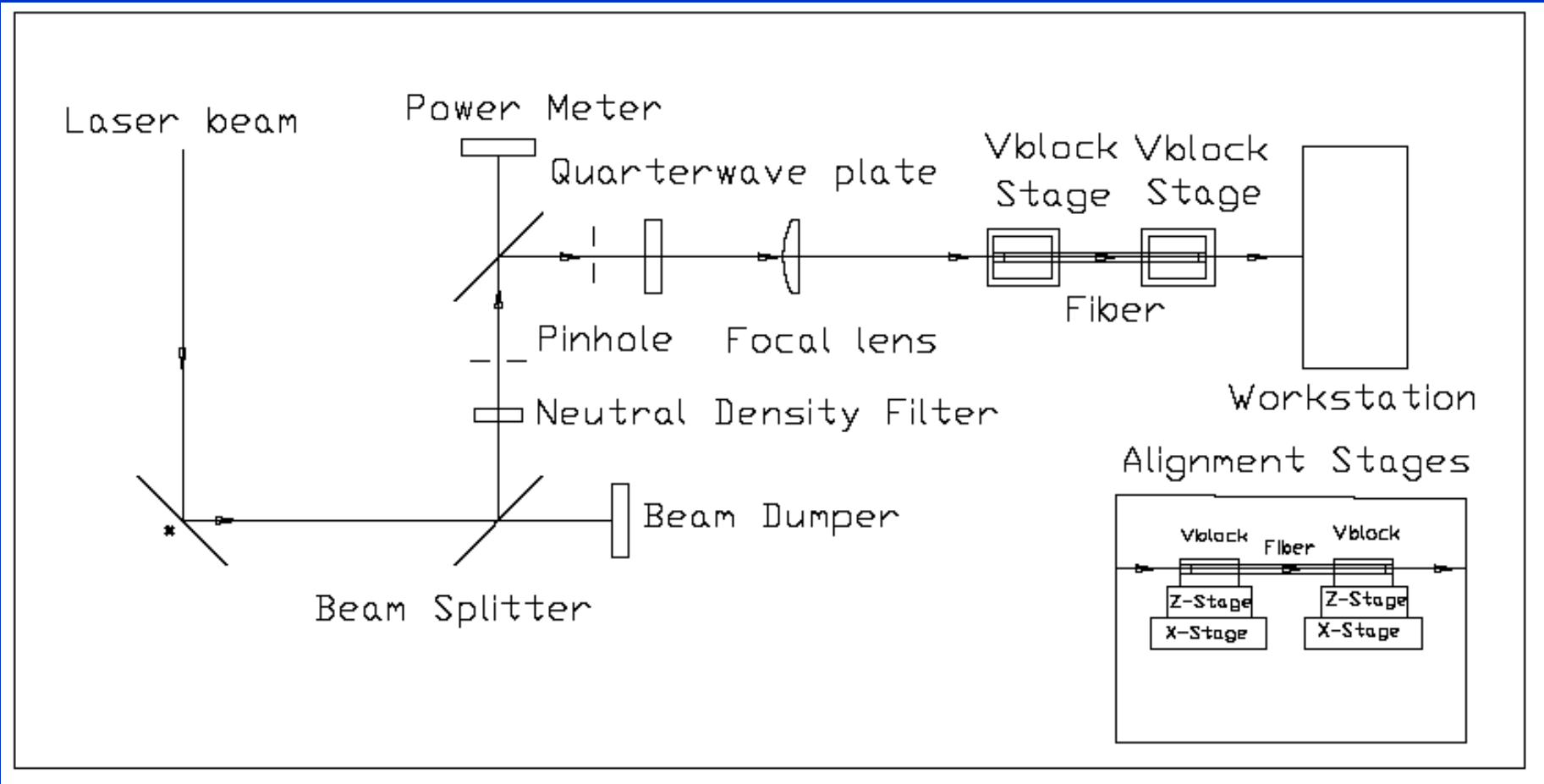

Accomplishments

Deep microdrilling in stainless steel in ambient air is successfully demonstrated using femtosecond laser pulses either delivered through a hollow-core fiber or focused by a lens. High aspect ratio (>10) microholes are made in 1 mm thick steel plates. The use of hollow fiber will definitely benefit some micromachining applications where conventional optics may not be feasible due to limited space, such as delivery of laser pulses through small holes or cavities.

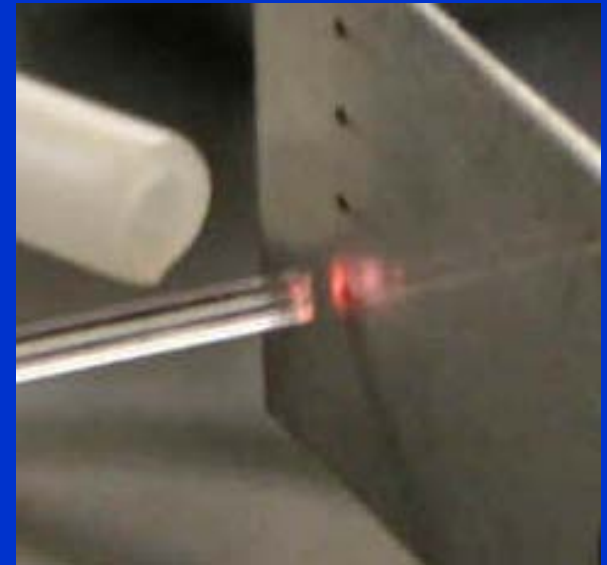
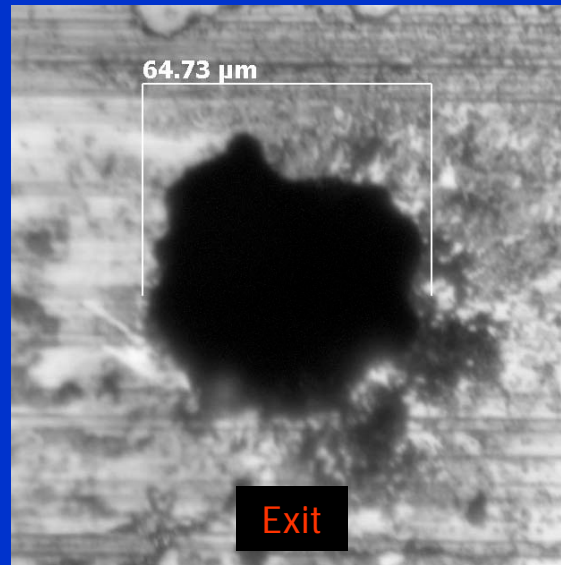
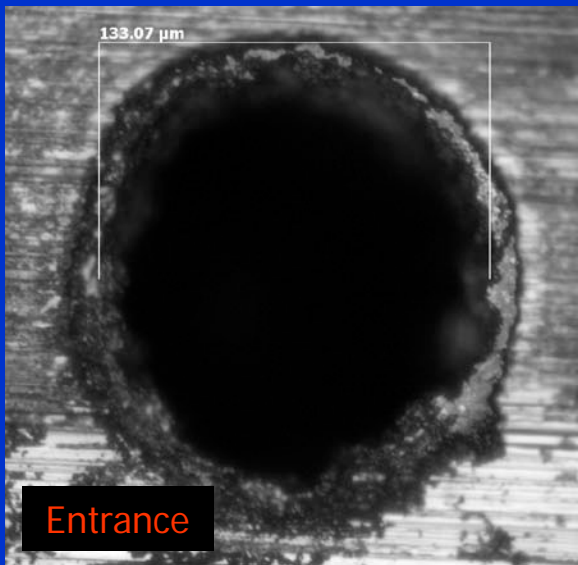

Summary and Significance

- Laser-hollow fiber coupling efficiency of more than 70% is achieved. The transmitted energy is limited mainly by air ionization which distorts the beam in space and time prior to entering into the fiber.
- High aspect ratio microholes are successfully produced with fs pulses delivered through hollow fiber. Ablation rate generally increases with decreasing pulse duration and increasing pulse energy. Heat affected zone is apparent on the entrance side.
- This project will establish femtosecond laser micromachining as a direct, flexible and single-step process for efficient production of high aspect ratio microstructures with high quality and low cost, which will open up opportunities for many new devices and products in aerospace, automotive, electronics and biomedical areas. For example, femtosecond laser micromachining may provide a practical solution for manufacturing microholes for fuel injection and cooling holes for gas turbines to reduce fuel consumption.

Micromachining of Polyurea Aerogel Using Femtosecond Laser Pulses

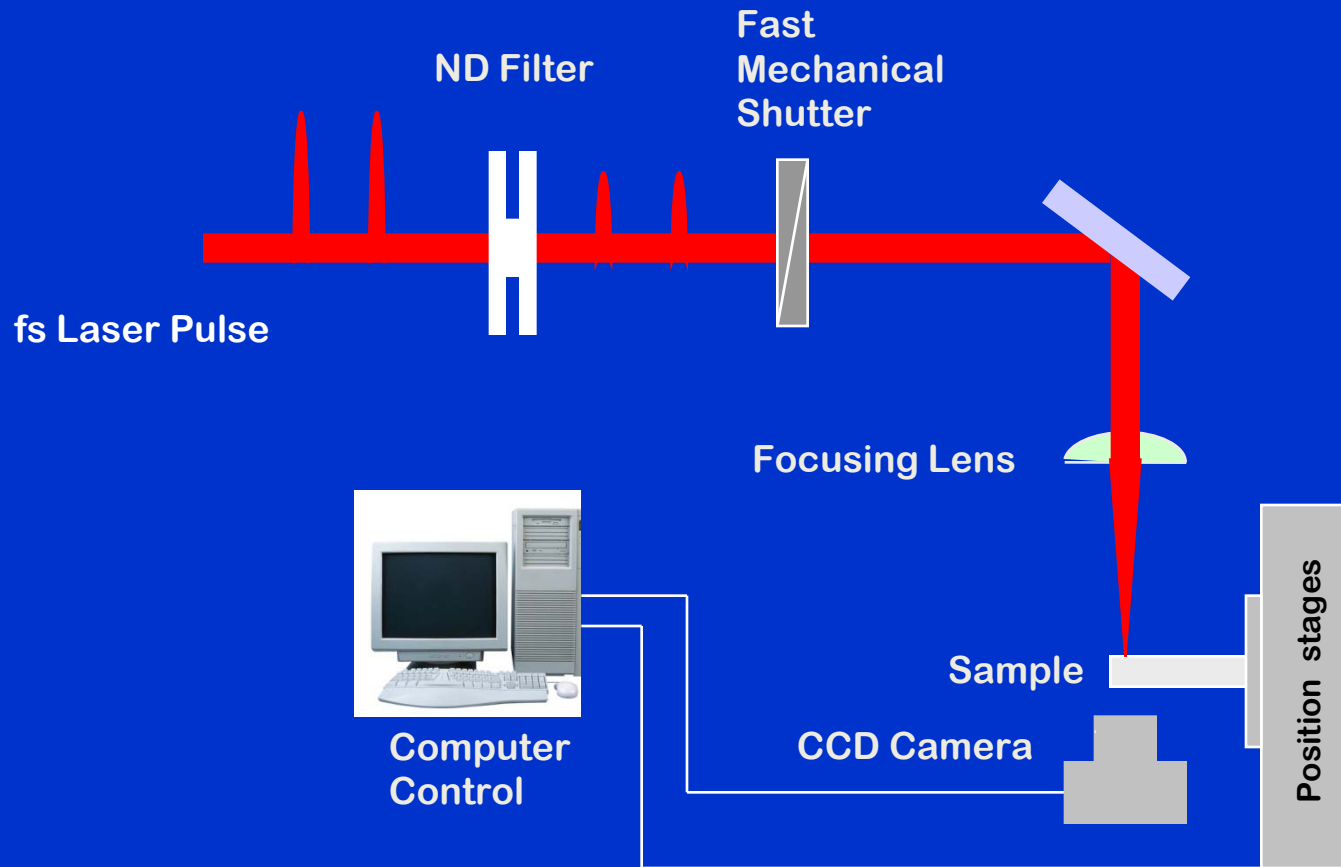

Accomplishments

We successfully sliced 10~15mm thick cylindrical polyurea aerogels into 1~3mm disks using femtosecond laser pulses. The material breakdown threshold is found to be $0.55\text{J}/\text{cm}^2$ at 800nm center wavelength and 40fs pulse width. The periodic surface structure after laser cutting is believed to be caused by material melting and vaporization. The affected layer of the cut surface is less than 10um thick, due to the ultra short laser pulse duration.



Samples

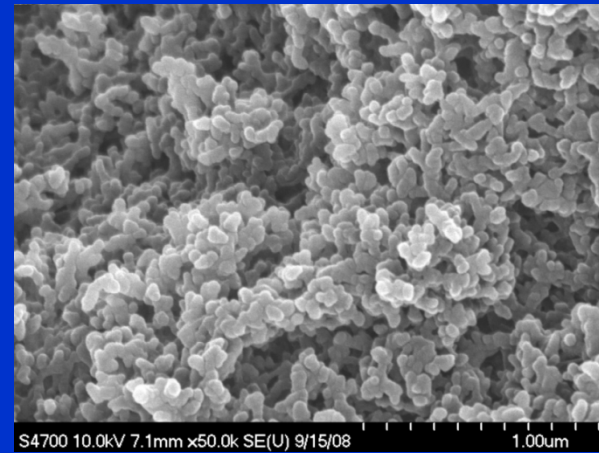

Microstructure

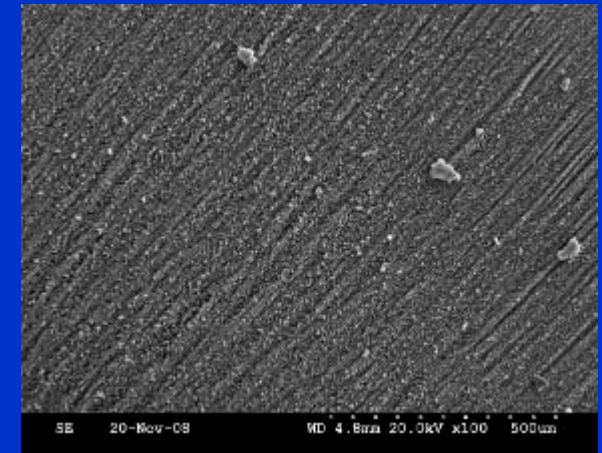

Cut surface

Summary and Significance

- The material breakdown threshold is found to be 1.7 J/cm^2 at 800 nm center wavelength and 40 fs pulse width. The material ablation rate at different energy levels is found to be on the order of tens of microns per pulse.
- The following parametric regime produces a high quality surface: the suitable beam fluence is $6.36\sim 7.6 \text{ J/cm}^2$ while the sample is translated at the speed of $0.1\sim 0.12 \text{ mm/s}$ and $5.1\sim 6.36 \text{ J/cm}^2$ while the sample is rotated at the speed of $3.5\sim 4 \text{ deg/s}$.
- Femtosecond laser will be established as a unique tool for shaping this type of highly porous materials. The unique porous structure of polyurea aerogel has many attractive applications including lightweight, thermal and acoustic insulation, radiation shielding, and vibration damping. For example, polyurea aerogel can be used to make composite materials for enhanced acoustic insulation in future aircraft structures for both military and commercial sectors.

Acknowledgements

- ARO/DoD
- Dr. Byung-Tai Kim, Chengju University, Korea
- Dr. Hongbing Lu, OSU
- Dr. Nicholas Leventis, Missouri University of Science and Technology